

TECHNICAL DATA SHEET -Light Weight Ceiling Mounting Bracket



DESIGN DRIVEN MANUFACTURING
SINCE 1927

PRODUCT NUMBER: LDC-1

Light Weight Ceiling Mounting Kit provides support for LCD/DLP hanging brackets and certain other products weighing up to 140 pounds.

FEATURES:

- Heavy gauge cold rolled steel construction
- NPT thread for attaching LCD/DLP mounts
- Ceiling tray is designed to fit above conventional suspended ceiling system.
- Turnbuckles allow the installation to be fine-tuned.

LDC-1 COMPONENTS:

- Ceiling tray
- Ceiling bracket
- Center bolt ring with studs

LDC-KIT:

- Turnbuckle 1/4-20 with hook and loop (4)
- Anchor, concrete (4)
- Cable 1/8" 10 Ft
- Clamp wire rope
- Ring escutcheon (1)
- 10-24 x 5/8 screw (4)
- Screw lag eye (4)
- Wire 14 Ga. 20 Ft

COLOR:

- White powder coat finish

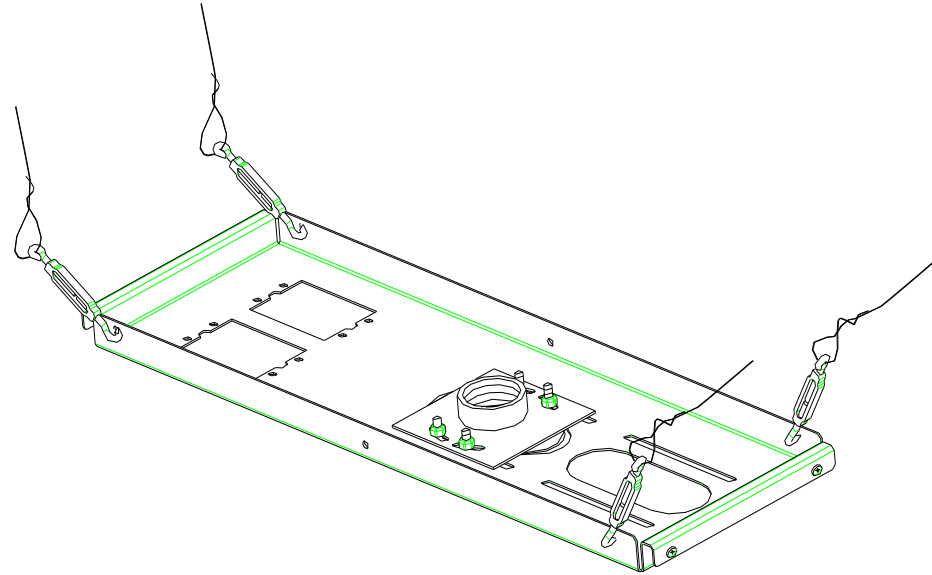

SPECIFICATIONS:

WEIGHT:

7 lbs (3.2 kg)

SHIPPING WEIGHT:

8 lbs (3.6 kg)

MAXIMUM LOAD CAPACITY:

140 lbs (63.5 kg)

SHIPPING CARTON DIMENSIONS:

L=25 1/2 in (648 mm)

W=11 1/4 in (286 mm)

H=1 3/4 in (44 mm)

ALL DIMENSION IN INCHES (MM)

CBM LTD.
1832 BONHILL RD.
MISSISSAUGA, ON
L5T 1C4
www.cbmmetal.com

CBM LTD.
4500 WITMER INDUSTRIAL ESTATES, #172
NIAGARA FALLS, N.Y.
14305-1386USA

TECHNICAL DATA SHEET -Light Weight Ceiling Mounting Bracket

PRODUCT NUMBER: LDC-1



DESIGN DRIVEN MANUFACTURING
SINCE 1927

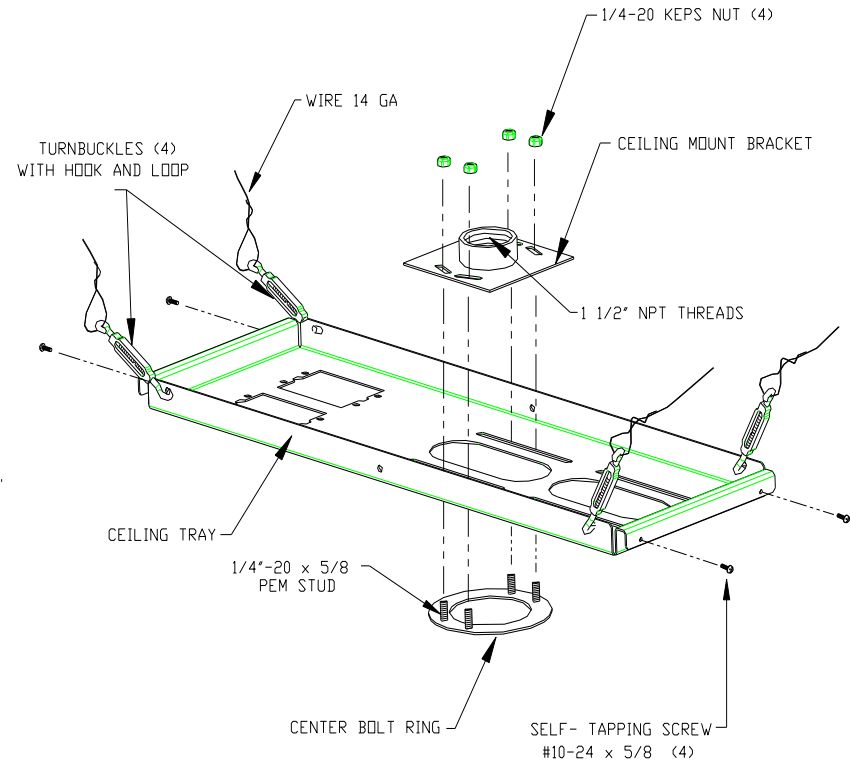
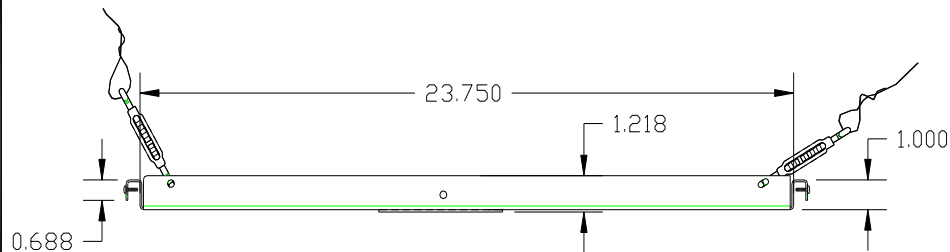
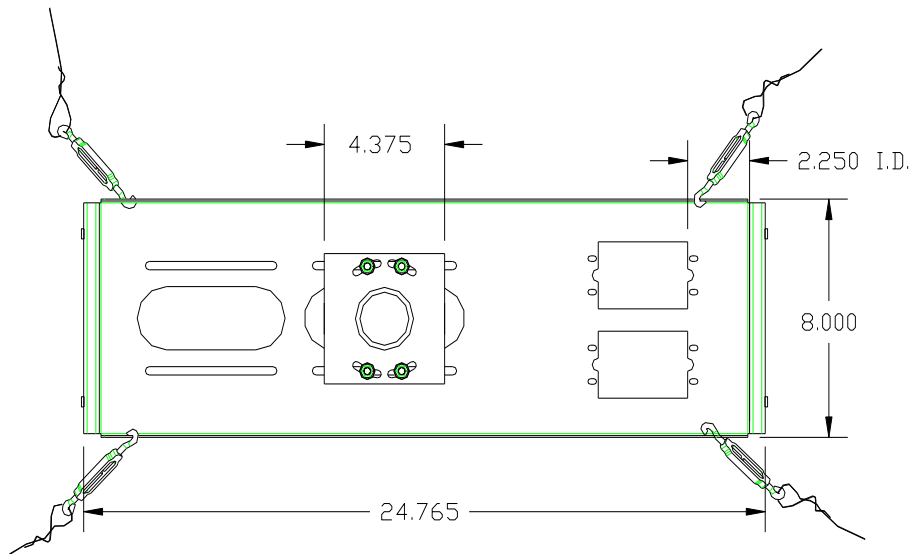

CBM LTD.
1832 BONHILL RD.
MISSISSAUGA, ON
L5T 1C4
www.cbmmetal.com

CBM LTD.
4500 WITMER INDUSTRIAL ESTATES, #172
NIAGARA FALLS, N.Y.
14305-1386USA